

Business & Market Outlook

Sep, 2011



The business results for the second quarter of 2011 currently under audit review are presented here for investors' convenience. Hence, please be advised that some of their contents may be altered in the course of audit.

Forecasts and projections contained in this material are based on current business environments and management strategies, and they may differ from the actual results upon changes and unaccounted variables.

From 2010, the business results are subject to the IFRS(International Financial Reporting Standards).

Table of Contents

LG Chem at a Glance	1
2Q 2011 Business Results	3
Divisional Results & Outlook	5
Appendix	7

LG Chem at a Glance

- LG Chem was started in 1947 and is Korea's first and largest chemical company with an established track of over 60 years and annual revenues of KRW 19.5 trillion in 2010
- LG Chem boasts multiple production facilities and an extensive distribution network that spans 15 countries worldwide in Asia, Europe, North and South America
- LG Chem currently holds the largest vertically integrated petrochemical production platform in Korea
- LG Chem was reborn as a specialized and diversified chemical company that focuses on petrochemical goods, rechargeable batteries including HEV/EV purpose, OLED materials, and 3D retarder
- LG Chem will seek operational excellence in its core business and centralize its resources with new business such as HEV/EV batteries and LCD glass to reinforce the necessary momentum for future growth.
- Despite high uncertainties remaining in the business environment such as a delayed recovery in the global economy, LG Chem recorded the highest sales and profits, in its history, in 2010

Impressive Revenue Scale.*

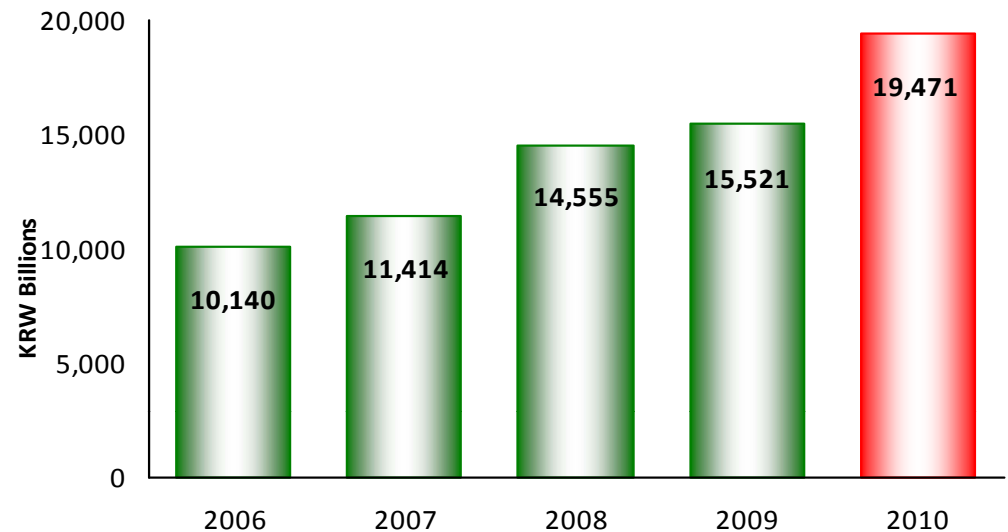

...with Strong EBIT & EBIT Margins*

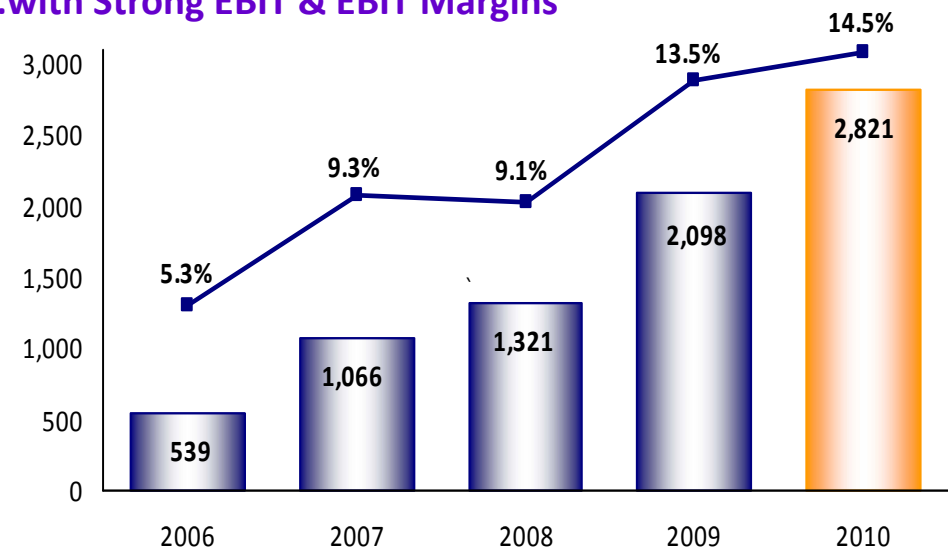

* Sales and EBIT are subject to IFRS from 2009. Those prior to 2009 are subject to K-GAAP(consolidated base).

Differentiated Competitiveness

Vertical Integration Structure

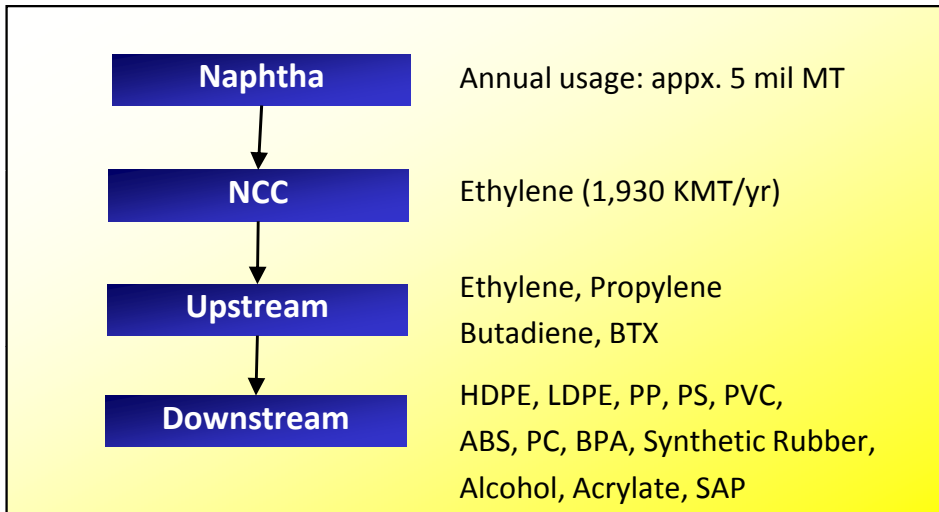

Co-existence of upstream and downstream products

- One of few petrochemical companies around the globe with a vertical integration structure, featuring both upstream and downstream production capability
- This structural characteristic delivers stable business performance against industry cyclicality

Comprehensive downstream product lines

LG Chem's comprehensive downstream product lines of PO, ABS, PVC and other various products have complementary business cycles, enabling the Company to generate stable revenue

Stabilized revenue generating capability under any market conditions

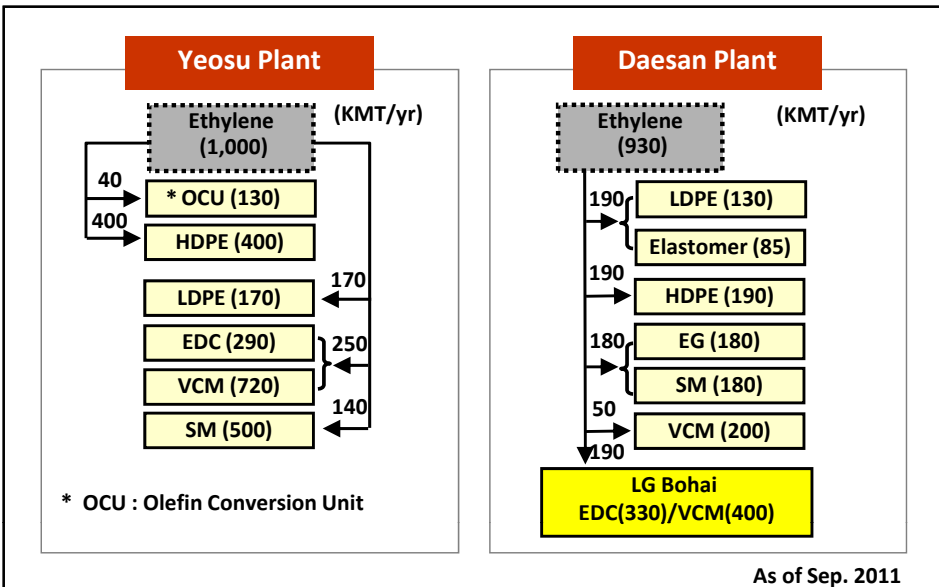

(Unit: KRW bn)

Classification	'10.2Q	'11.1Q	'11.2Q	YoY	QoQ
Sales	5,028	5,491	5,700	13.4%	3.8%
Operating Profits	828	835	775	-6.3%	-7.2%
(%)	(16.5)	(15.2)	(13.6)		
Pre-tax Income	822	841	786	-4.3%	-6.5%
(%)	(16.3)	(15.3)	(13.8)		
Net Income	646	657	625	-3.3%	-4.9%

Financial Position

(Unit: KRW bn)

Classification	'10	'11.2Q	Change
Asset	12,674	14,207	12.1%
Cash and equivalents	1,368	990	-27.6%
Liabilities	4,830	5,442	12.7%
Borrowings	2,101	2,450	16.6%
Shareholder's Equity	7,844	8,765	11.7%
EBITDA	3,495	1,975	

Financial Ratios

Classification	'10	'11.2Q	Change
Total Liabilities/ Equity (%)	61.6	62.1	0.5%p
Borrowings / Equity (%)	26.8	28.0	1.2%p
Interest Coverage Ratio (x)	46.0	49.3	3.3
ROE (%)	31.9	30.9	-1.0%p
ROA (%)	19.0	19.1	0.1%p

Business results

Analysis

(Unit: KRW bn)

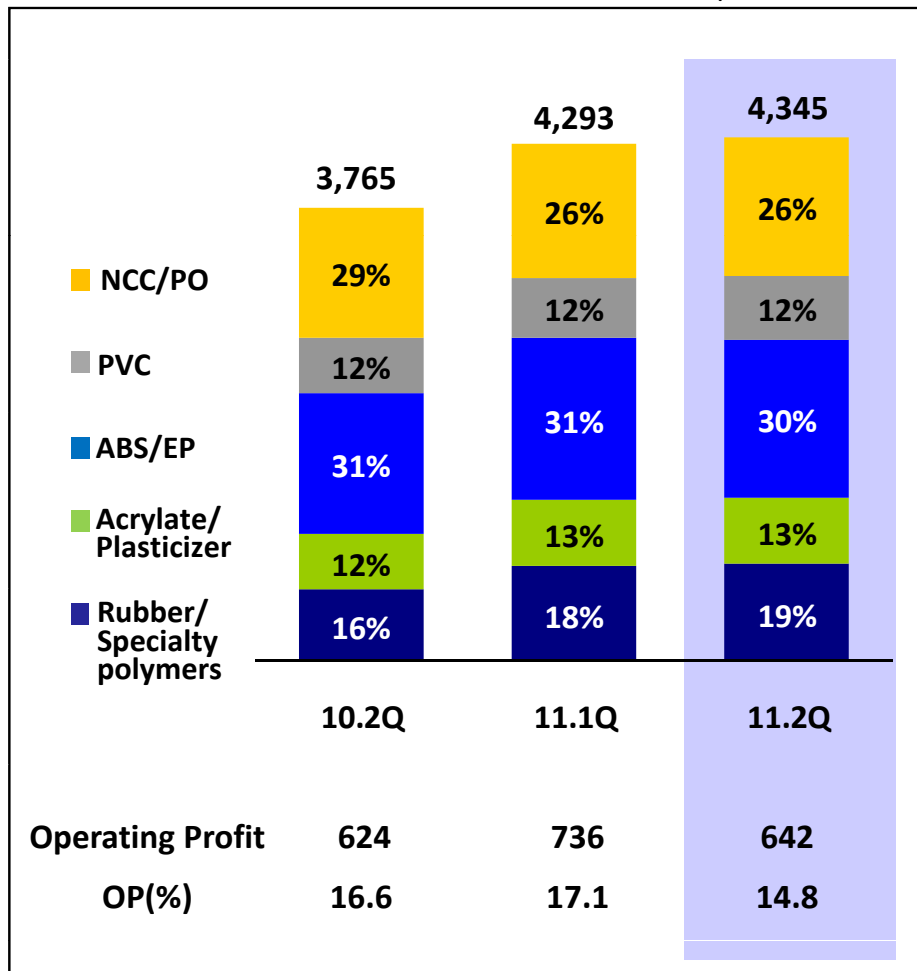

• Analysis

■ Achieved favorable business results despite weakened frontline industries

- NCC/PO : Maintained stable margin with PO premium products despite weak product prices
- PVC : Achieved high profit thanks to strong demand by peak seasonality and favorable market conditions such as India, etc.
- ABS/EP : Narrowed spread due to strong feedstock(BD, AN) prices and weak demand of frontline industries such as IT and others
- Acrylate / Plasticizer : Maintained high profitability thanks to tight supply market condition
- Rubber / Specialty polymers : Continued solid results caused by upswing of synthetic rubber demands

• Outlook

- Demand increase is expected due to seasonality
- Benefit from capacity expansions of competitive downstream products such as synthetic rubber, SAP and etc.

Business results

Analysis

(Unit: KRW bn)

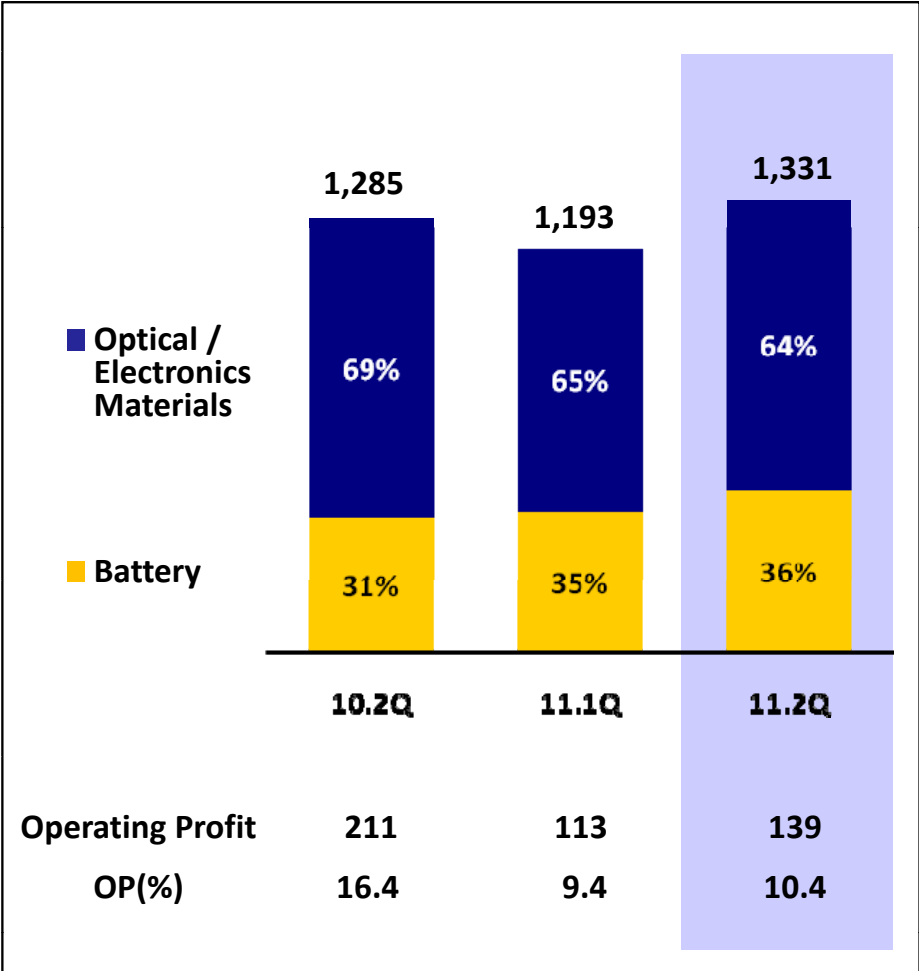

• Analysis

■ Improved profitability thanks to operating rate increase, new product sales growth and cost reduction despite weak IT demand

-Optical : Better profits thanks to gradual utilization rate increase mainly of super-wide polarizer lines and sales increase of 3D Retarder

-Battery : Improved earnings through expansion of polymer battery, internal share increase in strategic customers such as Apple and better product mix

• Outlook

■ Expect better profits based on growing IT demand & expansion of production capabilities of 3D Retarder and polymer battery

-Optical : Sales increase backed by seasonal IT demand and Materials completion of 3D Retarder production line

-Battery : Continuous demand growth for smart phones and tablet PCs & gradual improvement in business environments

(Unit: KRW bn)

Classification	2009					2010					2011		
	1Q	2Q	3Q	4Q	Total	1Q	2Q	3Q	4Q	Total	1Q	2Q	1H
Sales	3,350	3,830	4,295	4,046	15,521	4,423	5,028	5,021	4,999	19,471	5,491	5,700	11,191
Operating Profit	485	629	697	287	2,098	652	828	779	562	2,821	835	775	1,611
Petrochemicals	2,582	2,847	3,062	2,959	11,450	3,309	3,765	3,768	3,809	14,651	4,293	4,345	8,638
NCC/PO	751	836	911	897	3,395	948	1,082	1,068	1,018	4,116	1,108	1,152	2,260
PVC	439	416	429	408	1,693	453	455	455	489	1,852	500	517	1,017
ABS/EP	724	886	948	900	3,458	998	1,173	1,142	1,228	4,540	1,347	1,318	2,665
Acrylate/Plasticizer	310	324	351	330	1,315	401	451	478	429	1,760	549	550	1,099
Synthetic Rubber/ Specialty Resin	358	385	423	423	1,588	509	605	626	644	2,383	789	808	1,597
Operating Profit	380	511	491	226	1,608	490	624	621	544	2,279	736	642	1,378
I & E Materials	786	1,015	1,234	1,157	4,191	1,153	1,285	1,271	1,200	4,909	1,193	1,331	2,524
Optical/Electronic	556	724	862	774	2,916	843	917	913	832	3,504	807	891	1,698
Battery	248	317	445	375	1,385	347	414	394	399	1,552	432	500	932
Operating Profit	110	121	212	65	507	175	211	171	44	600	113	139	252

Borrowings

(Unit : KRW bn)

Classification	'10	'11.2Q
Total (Overseas Subsidiaries)	2,101 (824) 100%	2,450 (909) 100%
KRW Currency	162 8%	183 7%
C P	150	150
Others	12	33
Foreign Currency	1,940 92%	2,267 93%
Loan	936	1,042
Negotiation Borrowings	865	1,092
FRN	140	134
Short-term (Overseas Subsidiaries)	1,621 (559) 77%	2,247 (744) 92%
Long-term (Overseas Subsidiaries)	481 (265) 23%	203 (165) 8%

The % is calculated to total borrowings.

Cash Flow

(Unit: KRW bn)

Classification	'10	'11.2Q
Beginning Cash	1,107	1,368
Operating/Investing	810	-405
Net Income	2,200	1,281
Depreciation	656	365
Working Capital	-617	-849
CAPEX	-1,702	-1,156
Others	274	-45
Financing	-549	27
Borrowings	-269	349
Dividends	-280	-322
Ending	1,368	990

(Unit: KRW bn)

Classification		'09	'10	'11 Plan	'11.2Q (YTD)
Petrochemicals	New / Expansion	158	324	762	315
	Maintenance	132	237	263	150
	Total	290	560	1,025	465
I & E Materials	New / Expansion	472	814	973	514
	Maintenance	81	135	223	81
	Total	553	948	1,196	595
Common Expenses	New / Expansion	22	-	-	-
	Maintenance	198	193	145	97
	Total	221	193	145	97
Total	New / Expansion	652	1,138	1,735	829
	Maintenance	411	564	631	328
	Total	1,063	1,702	2,366	1,156

As of Sep, 2011

	Item	Location	Capa	Global Rank
Petro- Chemicals	ABS (Acrylonitrile-Butadiene-Styrene)	Korea, China	1,330 KMT/Yr	1st [*]
	PVC (Polyvinyl Chloride)	Korea, China	1,270 KMT/Yr	6th
	Oxo-Alcohol	Korea (Yeosu, Naju)	299 KMT/Yr	10th
	AA (Acrylic Acid)	Korea (Yeosu, Naju)	193 KMT/Yr	9th
	PC (Polycarbonate)	Korea (Yeosu)	170 KMT/Yr	6th
	BR (Butadiene Rubber)	Korea (Daesan)	180 KMT/Yr	7th
	Elastomer	Korea (Daesan)	85 KMT/Yr	4th
	SAP (Super Absorbent Polymer)	Korea (Gimcheon, Yeosu)	108 KMT/Yr	6th
	MBS (Methacrylate-Butadiene-Styrene)	Korea (Yeosu)	50 KMT/Yr	4th
	NBL (Acrylonitrile-Butadiene-Latex)	Korea (Yeosu)	100 KMT/Yr	2nd
	BPA (Bisphenol A)	Korea (Yeosu)	280 KMT/Yr	8th
I & E Materials	Polarizer	Korea (Ochang)	130 Million M ² /Yr	1st
	Consumer Battery (Lithium-ion)	Korea (Ochang)	78 Million Cells/Month	3rd
	EV/HEV Battery (Lithium-ion)	Korea (Ochang)	-	1st
	Color Filter Photoresists	Korea (Ochang)	-	2nd
	3D Retarder	Korea (Ochang)	-	1st

* Actual Sales Base

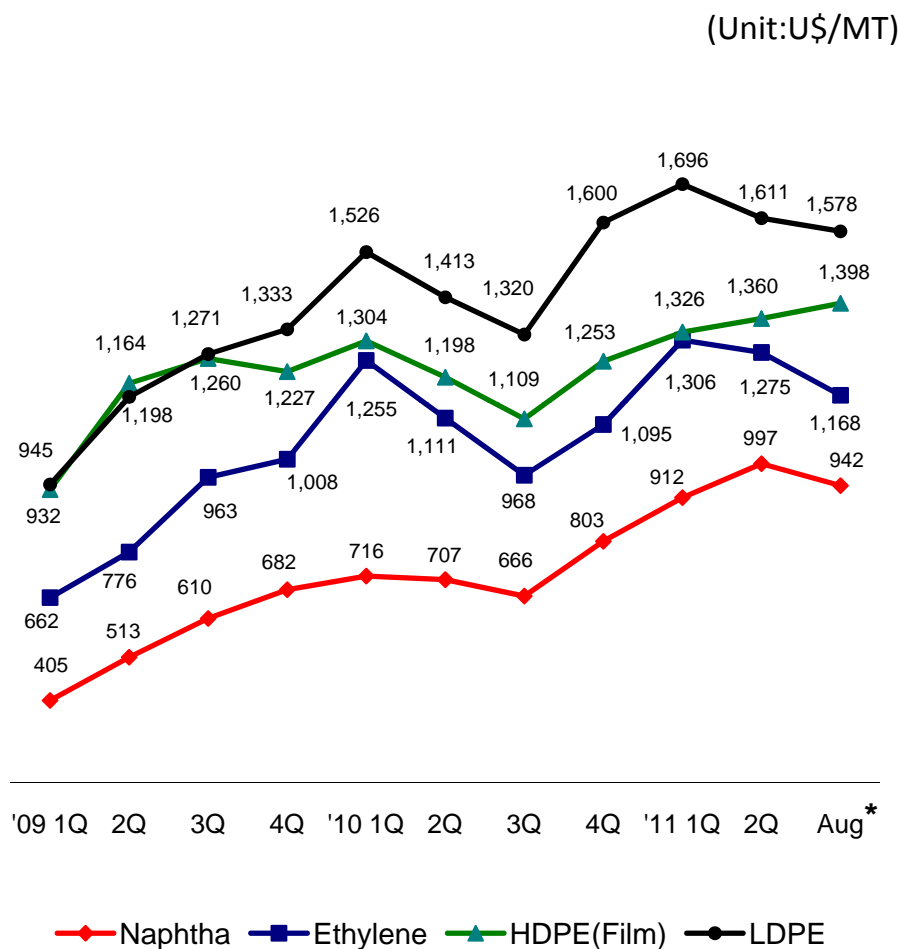

NCC/PO

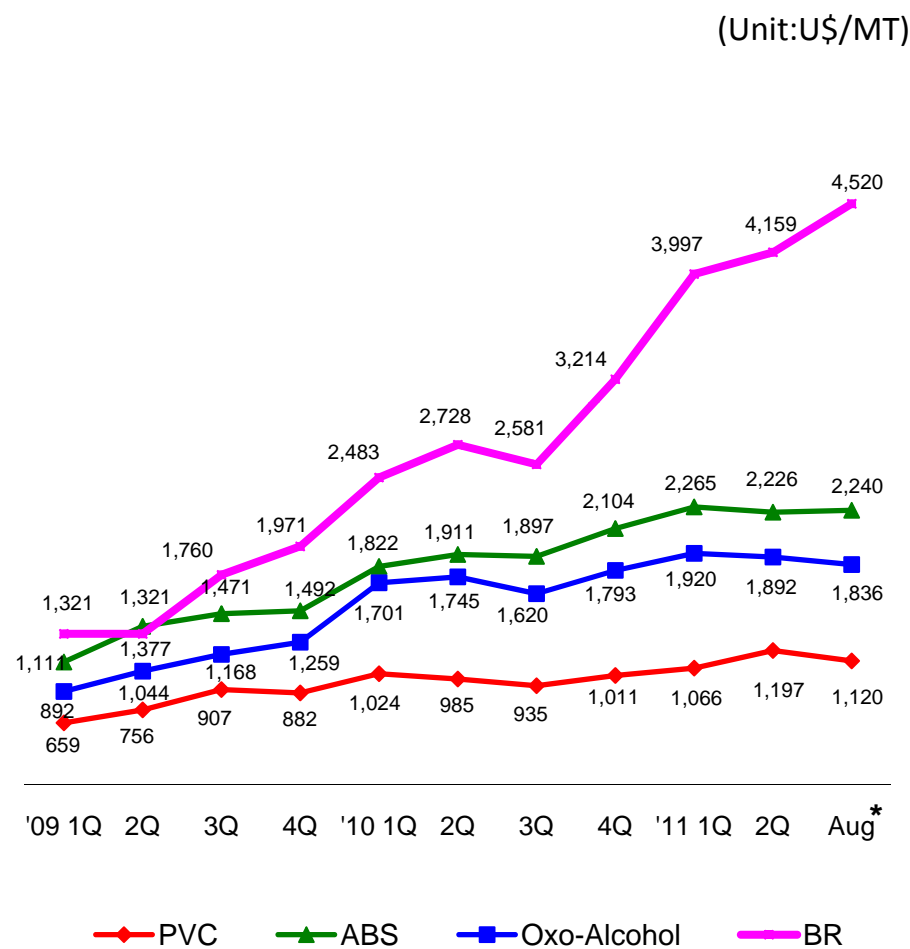

PVC

ABS/EP

Acrylate/
Plasticizer

Rubber/
Specialty Polymers

• Note: The prices are monthly average price of CFR FE Asia for general grade in each product group.

* shows average prices of Aug